

Inlet Vacuum Filters



Inlet Vacuum Filter Technical Data	pg. 4-2
"L" Style Compact Vacuum Filters	
CSL Series 3/8" - 3" BSPP, 31 - 510 m ³ /h	pg. 4-4
ISO Flg CSL Series NW16-K100, 31 - 510 m ³ /h	pg. 4-5
"L" Style Large Vacuum Filters	
CSL Series: 3" - 6" BSPT, 510 - 1870 m ³ /h	pg. 4-6
CSL Series: DN80 - DN300, 510 - 8415 m ³ /h	pg. 4-6
ISO Flg "L" Style Large Vacuum Filters	
CSL Series: K160 - K320, 1870 - 8415 m ³ /h	pg. 4-8
"T" Style Compact Vacuum Filters:	
ST Series: 1" - 4" BSPP, 68 - 884 m ³ /h	pg. 4-9
CT Series: 1" - 6" BSPP, 68 - 1870 m ³ /h	pg. 4-9
Extreme Duty SpinMeister Vacuum Filters	
STSML Series: 2" - 6" BSPP, 68 - 1530 m ³ /h	pg. 4-10
Reverse Pulse Extreme Duty Vacuum Filters	
RST Series: 2" - 4", 298 - 884 m ³ /h	pg. 4-11
Vacuum Filters for Medical (Non-Sanitary)	
HV Series: 2" - 4", 175 - 340 m ³ /h	pg. 4-12
See-Through Liquid Separators	
STS Series: 1" - 4", 68 - 850 m ³ /h	pg. 4-13
Vacuum Filtration for Solar, Semi-Con, LED, Coating	
Protecting Vacuum Pumps & Systems	pg. 4-14
RX Series: Reverse Pulse System	pg. 4-15
Liquid Separator/Vacuum Filters	
LRS Series: 2" - 4", 105 - 1415 m ³ /h	pg. 4-16
SRS Series: DN150 - DN250, 2170 - 3060 m ³ /h	pg. 4-16
Natural Gas Filtration Suction Scrubbers	
Pressure Drop Gauges	pg. 4-19

Applications & Equipment

- Industrial & Severe Duty
- Vacuum Pumps & Systems: Roots, Rotary Vane, Screw, Piston
- Vacuum Packaging Equipment
- Vacuum Furnace
- Blowers: Side Channel & Roots
- Vacuum Lifters
- Intake Suction Filters
- Food Industry
- Woodworking/Routers
- Ash Handling
- Printing Industry
- Medical/Hospital
- Remote Installations for Piston & Screw Compressors
- Paper Processing
- Waste Water Aeration
- Cement
- Bag House Systems
- Vacuum Vent Breathers
- Chemical Processing
- Factory Automation Equipment
- Leak Detection Systems
- Inquires Encouraged

Identification

All Solberg products should have an identification label/nameplate that gives the following information:

Assembly Model #

Replacement Element #

The part number designates the filter type, the element configuration and housing connection size. For example, the following part number identifies the filter as being a “CSL” design filter with a “235” element, “P” prefilter and DN100 flange connection size.

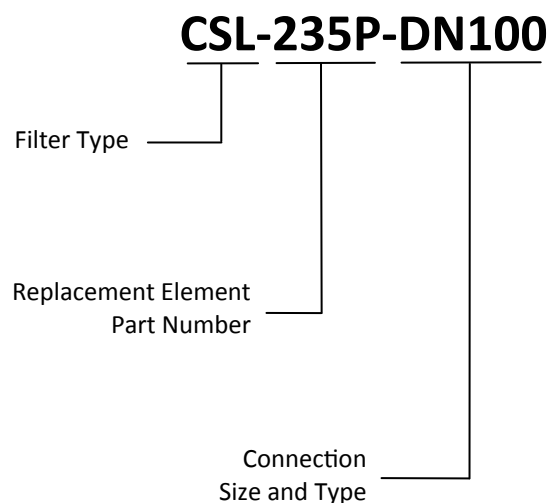

Choosing the Best Filter for your Equipment

A. Connection & Airflow known:

1. Select appropriate **BSPT Outlet or FLG Outlet** and check **Assembly m³/h Rating**. Compare with your required airflow. *Note: Assembly m³/h ratings are based on 30m/sec or 6,000 FPM for a given connection size to achieve low pressure drop performance. When required flow exceeds Assembly m³/h rating, the pressure drop through the outlet connection will increase. In such cases select by element flow rating.*
2. Go to "C. Selecting Elements"

B. Connection size is unknown or flexible:

Go to "C. Selecting Elements"

C. Selecting Elements: Element selection is based on application duty Standard media are:

Polyester: all purpose; withstands pulses, moistures & oily air

Paper: mostly dry, smooth flow

applications

When required flow rating (m³/h) matches connection size:

1. Multiple elements are offered to be selected by Duty (See Duty Descriptions below)
 2. Match element with anticipated Duty
- D. When required flow rating (m³/h) exceeds assembly flow rating or connection size is unknown:**

1. Match required flow rating with **Element Flow Rating**
2. Review application by Duty and upsize accordingly
3. Choose connection size

Application Duty Descriptions: Regular maintenance checks and proper servicing is required. Actual performance is influenced by the Application Duty:

Industrial Duty = clean workshop or clean outdoor environment-small element sizing is sufficient.

Severe Duty = dirty workshop, wastewater- medium to large element is recommended.

Extreme Duty = Cement, steel making, plastics or dusty material conveying – Largest element sizing is recommended.

Element Maintenance

Solberg elements should be cleaned or replaced, once the pressure drop reaches 37-50 mbar above the initial pressure drop of the installation.

The decision to clean the element rather than replace it is left to the discretion of the operator. Any damage which results from by-pass or additional pressure drop created by element cleaning is the sole responsibility of the operator.

Note: The overall performance of a filter element is altered once cleaned. The initial pressure drop after subsequent cleanings will be greater than the original, clean pressure drop of the element. After each cleaning, the pressure drop will continue to increase. Under all circumstances, the initial pressure drop of the element needs to be maintained at less than 37 mbar.

Once the element has been cleaned, if the pressure drop exceeds 50 mbar at start-up; it must be replaced with a new element. With many types of equipment, the maximum pressure drop allowed will be dictated by the ability of the equipment to perform to its rated capacity. Under all circumstances, the operator should avoid exceeding the manufacturer's recommended maximum pressure drop for their specific equipment.

"L" Style Vacuum Filters CSL Series 3/8" - 3" BSPP

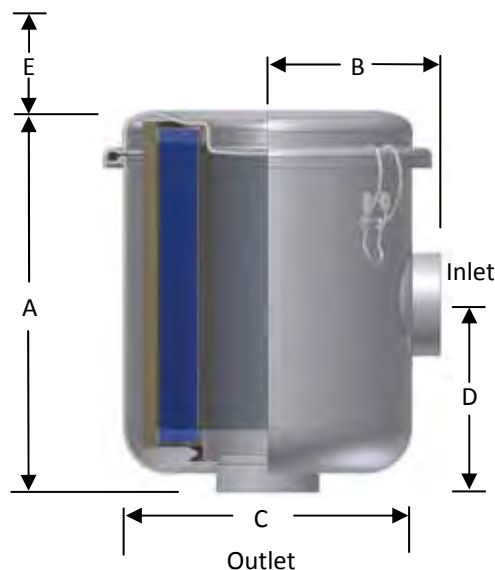

Features

- Seamless drawn housings
- Brazed fittings for high vacuum duty
- Stainless steel torsion clips for durability
- Positive engagement O-ring seal system
- Rugged all steel construction with baked enamel finish

Benefits

- Large dirt holding capacity and easy field cleaning, especially when mounted horizontally or inverted
- Designed to handle high vacuum applications
- Low pressure design

Technical Specifications

- Vacuum Rating: Gas tight o-ring seal
- Temp (continuous): min -26°C (-15°F) max 104°C (220°F)
- Filter change out differential: 37-50 mbar over initial ΔP
- Polyester: 99%+ removal efficiency standard to 5 micron
- Paper: 99%+ removal efficiency standard to 2 micron

Options

- Vacuum gauge
- Dome hood for high holding capacity
- Material/Finishes: stainless steel, epoxy coating
- Support brackets
- Alternative top-to-canister fastening system for low pressure or pulsating systems

BSPP Outlet Connections

Inlet/ Outlet Size	Inlet/ Outlet Type	Assembly m ³ /h Rating	Assembly Part Number		Dimensions - mm				Suggested Service HT. E	Approx. Weight kg	Replacement Element Part No.		Element m ³ /h Rating
			Polyester	Paper	A	B	C	D			Polyester	Paper	
3/8"	BSPP	31	CSL-825-039HCB	CSL-824-039HCB	92	57	95	48	76	0.40	825	824	43
1/2"	FPT	31	CSL-825-050HCB	CSL-824-050HCB	92	57	95	48	76	0.40	825	824	43
1/2"	FPT	34	CSL-843-050HCB	CSL-842-050HCB	111	76	149	64	83	1.4	843	842	94
3/4"	FPT	41	CSL-825-075HCB	CSL-824-075HCB	95	57	95	48	76	0.40	825	824	43
3/4"	FPT	43	CSL-843-075HCB	CSL-842-075HCB	111	76	149	64	83	1.4	843	842	94
1"	BSPP	60	CSL-843-101HCB	CSL-842-101HCB	111	83	149	67	83	1.4	843	842	94
1"	BSPP	68	CSL-849-101HCB	CSL-848-101HCB	171	105	186	114	133	2.3	849	848	196
1 1/4"	BSPP	94	CSL-843-126HCB	CSL-842-126HCB	111	83	149	67	83	1.4	843	842	94
1 1/4"	BSPP	102	CSL-849-126HCB	CSL-848-126HCB	171	105	186	114	133	2.3	849	848	196
1 1/2"	BSPP	136	CSL-849-151HCB	CSL-848-151HCB	171	105	186	114	133	2.3	849	848	196
2"	BSPP	298	CSL-851-201HCB	CSL-850-201HCB	260	116	222	127	235	6.8	851	850	493
2 1/2"	BSPP	357	CSL-851-251HCB	CSL-850-251HCB	267	130	222	140	235	6.8	851	850	493
3"	BSPP	510	CSL-239-301HCB	CSL-238-301HCB	400	226	337	222	279	15	239	238	969

See Vacuum Filter Technical Data section for sizing guidelines.

Note: FPT threaded housings are interchangeable with BSPP up to 1".

Dimension tolerance ± 6 mm

Note: Model offerings and design parameters may change without notice. See www.solbergmfg.com for most current offering.

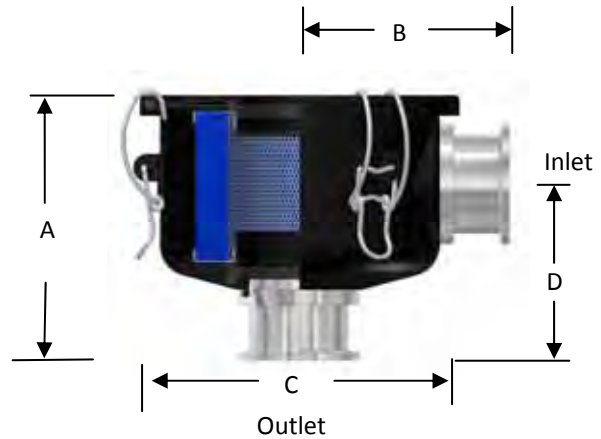

Features

- ISO flange stainless steel connections
- Rugged steel construction with baked enamel finish
- Stainless steel torsion clips for durability
- Positive engagement O-ring seal system
- Seamless drawn housings

Technical Specifications

- Vacuum Leak Rate: 1×10^{-5} mbar l/sec
- Temp (continuous): min -26°C (-15°F) max 104°C (220°F)
- Filter change out differential: 37-50 mbar over initial ΔP
- Polyester: 99%+ removal efficiency standard to 5 micron
- Paper: 99%+ removal efficiency standard to 2 micron

Series Specific Applications

- Prevent dry scroll tip seal migration
- Polycrystalline silicone ingot production
- Vacuum coating
- Solar cell lamination
- Trap condensable vapors
- Thin-film manufacturing
- Protect against backstreaming (Foreline Trap)

Options (Inquires Encouraged)

- Contact factory for larger sizes
- ATEX certification
- Viton seals
- Electroless nickel finish
- Stainless steel



Electroless Nickel Finish

SS ISO Flange w/Black Finish (Contact factory for availability)

ISO Flg Inlet & Outlet	Assembly m ³ /h Rating	Assembly Part Number		Dimensions - mm				Approx. Weight kg	Replacement Element Part No.		Element m ³ /h Rating
		Polyester	Paper	A	B	C	D		Polyester	Paper	
NW16	39	CSL-825-NW16B	CSL-824-NW16B	99	67	95	58	0.4	825	824	42
NW16	42	CSL-825-NW25B	CSL-824-NW25B	99	67	95	58	0.4	825	824	42
NW25	59	CSL-843-NW25B	CSL-842-NW25B	111	86	146	70	1	843	842	93
NW40	93	CSL-843-NW40B	CSL-842-NW40B	111	86	146	70	1	843	842	93
NW40	136	CSL-849-NW40B	CSL-848-NW40B	183	117	187	127	2	849	848	195
K63	357	CSL-851-K63	CSL-850-K63	292	155	195	165	7	851	850	493

SS ISO Flange w/Electroless Nickel Finish (Contact factory for availability)

ISO Flg Inlet & Outlet	Assembly m ³ /h Rating	Assembly Part Number		Dimensions - mm				Approx. Weight kg	Replacement Element Part No.		Element m ³ /h Rating
		Polyester	Paper	A	B	C	D		Polyester	Paper	
NW16	39	CSL-825-NW16EN	CSL-824-NW16EN	99	67	95	58	0.4	825	824	42
NW16	42	CSL-825-NW25EN	CSL-824-NW25EN	99	67	95	58	0.4	825	824	42
NW25	59	CSL-843-NW25EN	CSL-842-NW25EN	111	86	146	70	1	843	842	93
NW40	93	CSL-843-NW40EN	CSL-842-NW40EN	111	86	146	70	1	843	842	93
NW40	136	CSL-849-NW40EN	CSL-848-NW40EN	183	117	187	127	2	849	848	195
K63	357	CSL-851-K63EN	CSL-850-K63EN	292	155	195	165	7	851	850	493

See Vacuum Filter Technical Data section for sizing guidelines.

Dimension tolerance ± 6 mm

Note: Model offerings and design parameters may change without notice. See www.solbergmfg.com for most current offering.

"L" Style Vacuum Filters CSL Series 3"- DN300 BSPT, Flange

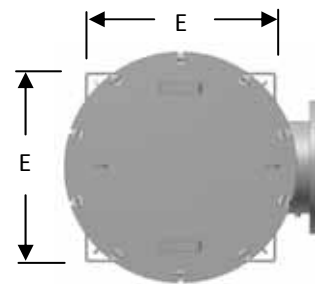
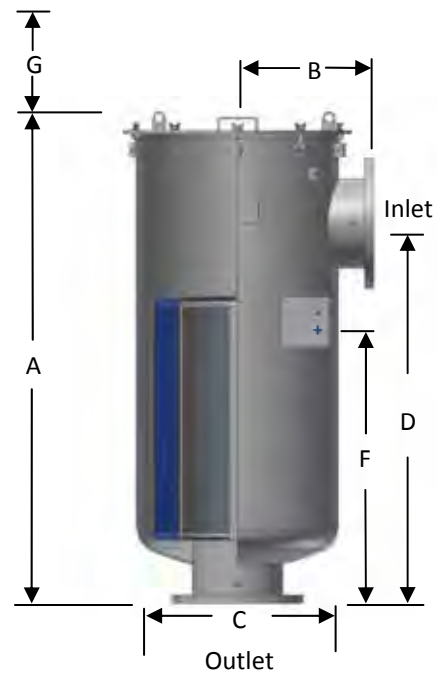

Features

- Heavy duty T bolts for easy maintenance
- Rugged all steel construction w/baked enamel finish
- Positive engagement O-ring seal system
- Inlet & outlet 1/4" gauge taps
- Lifting lugs
- Brackets for optional support legs
- Nameplate bracket

Benefits

- Large dirty holding capacity and easy field cleaning, especially when mounted horizontally or inverted
- Low pressure drop construction

Options

- Straight-through configurations
- Various filter media
- Material/Finishes: Stainless steel, Epoxy coating
- Custom connections
- PN6, PN16 flange patterns
- Flange faces free of paint
- Internal surfaces free of paint

Technical Specifications

- Vacuum Rating: Gas tight o-ring seal
- Hydrostatically tested to 0.5 bar pressure for vacuum seal
- Temp (continuous): min -26°C (-15°F) max 104°C (220°F)
- Filter change out differential: 37-50 mbar over initial ΔP
- Polyester: 99%+ removal efficiency standard to 5 micron
- Paper: 99%+ removal efficiency standard to 2 micron

PN10 Pattern Flange Outlet Connections

Flange Inlet & Outlet	Assembly m ³ /h Rating	Assembly Part Number		Dimensions - mm						Suggested Service HT. G	Approx. Wt. Kg	Replacement Element Part No.		Element m ³ /h Rating
		Polyester	Paper	A	B	C	D	E	F			Polyester	Paper	
DN80	510	CSL-235P-DN80	CSL-234P-DN80	689	229	356	470	299	314	305	28	235P	234P	970
DN80	510	CSL-335P-DN80	CSL-334P-DN80	689	229	356	470	299	314	432	29	335P	334P	1360
DN100	885	CSL-235P-DN100	CSL-234P-DN100	689	229	356	470	303	305	305	28	235P	234P	970
DN100	885	CSL-335P-DN100	CSL-334P-DN100	689	229	356	470	303	305	432	29	335P	334P	1360
DN125	1360	CSL-245P-DN125	CSL-244P-DN125	714	279	470	495	376	346	305	40	245P	244P	1500
DN125	1360	CSL-345P-DN125	CSL-344P-DN125	724	279	470	495	376	346	432	41	345P	344P	1870
DN150	1870	CSL-275P-DN150	CSL-274P-DN150	740	305	470	521	377	400	305	50	275P	274P	1870
DN150	1870	CSL-375P-DN150	CSL-374P-DN150	740	305	470	521	377	400	432	51	375P	374P	2550
DN200	3060	CSL-377P-DN200	CSL-376P-DN200	965	356	572	648	489	437	432	83	377P	376P	3105
DN250	4930	CSL-385P-DN250	CSL-384P-DN250	1130	410	686	864	567	598	432	115	385P	384P	5610
DN300	7990	CSL-485P-DN300	CSL-484P-DN300	1130	410	686	864	567	622	610	125	485P	484P	8000
DN250	4930	CSL-685P-DN250	CSL-384P(2)-DN250*	1461	406	672	1143	567	876	787	171	685P	384P(2)*	11220
DN300	8415	CSL-685P-DN300	CSL-384P(2)-DN300*	1461	406	672	1143	567	876	787	171	685P	384P(2)*	11220
DN300	8415	CSL-485P(2)-DN300*	CSL-484P(2)-DN300*	1765	406	672	1448	558	673	610	209	485P(2)*	484P(2)*	16000

See Vacuum Filter Technical Data section for sizing guidelines.
 * Denotes 2 elements stacked in housing.

Dimension tolerance ± 6 mm

PN10 Pattern Flange	Dimensions - mm			No. of Holes	Thickness Flg mm
	O.D.	B.C.	B.H.		
DN 80	200	160	18	8	20
DN100	220	180	18	8	20
DN125	250	210	18	8	22
DN150	285	240	22	8	22
DN200	340	295	22	8	24
DN250	395	350	22	12	26
DN300	445	400	22	12	26

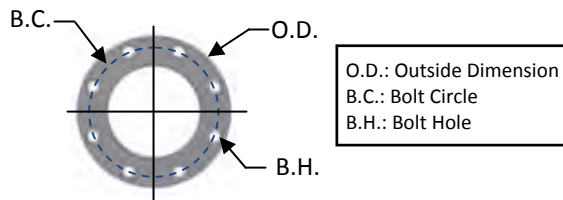

All flanges are orientated "split center".

BSPT Connections

BSPT Inlet & Outlet	Assembly m ³ /h Rating	Assembly Part Number		Dimensions - mm						Suggested Service HT. G	Approx. Weight kg	Replacement Element Part No.		Element m ³ /h Rating
		Polyester	Paper	A	B	C	D	E	F			Polyester	Paper	
3"	510	CSL-235P-301	CSL-234P-301	689	229	356	470	299	314	305	21	235P	234P	970
3"	510	CSL-335P-301	CSL-334P-301	689	229	356	470	299	314	432	23	335P	334P	1360
4"	885	CSL-235P-401	CSL-234P-401	689	229	356	470	303	314	305	23	235P	234P	970
4"	885	CSL-335P-401	CSL-334P-401	689	229	356	470	303	314	432	25	335P	334P	1360
5"	1360	CSL-245P-501	CSL-244P-501	714	279	470	495	376	375	305	37	245P	244P	1500
5"	1360	CSL-345P-501	CSL-344P-501	714	279	470	495	376	375	432	40	345P	344P	1870
6"	1870	CSL-275P-601	CSL-274P-601	740	305	470	521	376	375	305	43	275P	274P	1870
6"	1870	CSL-375P-601	CSL-374P-601	740	305	470	521	376	375	432	44	375P	374P	2550

See Vacuum Filter Technical Data section for sizing guidelines.

Dimension tolerance ± 6 mm

"L" Style Vacuum Filters

ISO CSL Series K160 - K250 Flange

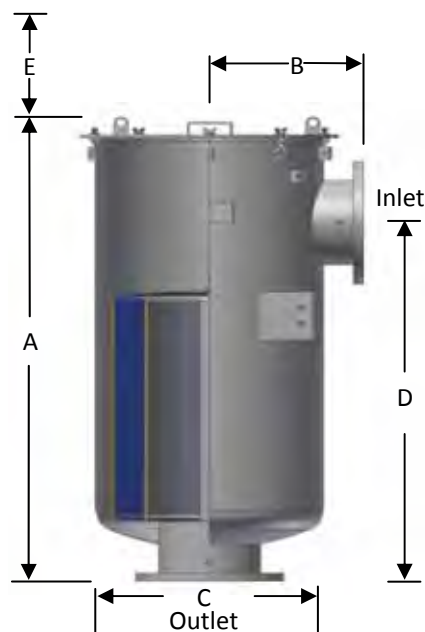

Features

- Stainless steel ISO flange connections
- High conductance/low pressure drop design
- Rugged all steel construction with baked enamel finish
- Heavy duty T bolts for easy maintenance
- Lifting lugs
- Brackets for optional support legs
- Nameplate bracket

Series Specific Applications

- Polycrystalline silicone ingot production
- Vacuum coating
- Solar cell lamination
- Vacuum furnaces
- Thin-film manufacturing

Technical Specifications

- Vacuum Leak Rate: 1×10^{-5} mbar l/sec
- Temp (continuous): min -26°C (-15°F) max 104°C (220°F)
- Filter change out differential: 37-50 mbar over initial ΔP
- Polyester: 99%+ removal efficiency standard to 5 micron
- Paper: 99%+ removal efficiency standard to 2 micron

Options

- ATEX certification
- Industrial coatings: Teflon, Epoxy, Kynar, plating
- Material: stainless steel
- Various filter media
- ISO F flanges

ISO Flange Outlet Connections

ISO Flg Inlet & Outlet	Assembly m ³ /h Rating	Assembly Part Number		Dimensions - mm				Suggested Service HT.	Approx. Weight kg	Replacement Element Part No.		Element m ³ /h Rating
		Polyester	Paper	A	B	C	D			Polyester	Paper	
K160	1870	CSL-275P-K160	CSL-274P-K160	734	305	470	521	305	50	275P	274P	1870
K160	1870	CSL-375P-K160	CSL-374P-K160	734	305	470	521	432	51	375P	374P	2550
K200	3060	CSL-377P-K200	CSL-376P-K200	1017	356	572	648	432	83	377P	376P	3105
K250	4930	CSL-385P-K250	CSL-384P-K250	1214	410	686	864	432	115	385P	384P	5610
K320	7930	CSL-485P-K320	CSL-484P-K320					610	125	485P	484P	8000
K320	8415	CSL-685P-K320	CSL-384P(2)-K320*	Contact Solberg for dimensions				787	171	685P	384P(2)*	11220

See Vacuum Filter Technical Data section for sizing guidelines.

Dimension tolerance ± 6 mm

Note: Model offerings and design parameters may change without notice. See www.solbergmfg.com for most current offering.

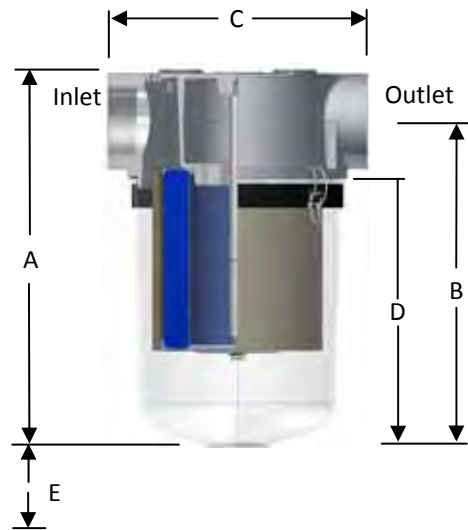

General Features

- Compact design for space restrictions; min. service area
- Inlet above element for extended element life & maintenance intervals
- Cast, corrosion resistant aluminum top with machined connections: - Integrated baffle design
- "T" style design minimizes piping requirements
- 2" to 6" only: 4 M12 taps for mounting brackets
1/4" differential gauge ports:

ST Series Specifications

- See-through bucket made from polycarbonate material
- Bucket has a high tensile strength for dimensional stability
- Temp ratings: - Complete assembly max: 104°C (220°F)
- See-through bucket only max: 125°C (257°F)
- Increased holding capacity

Technical Specifications

- Vacuum Rating: Gas tight seal
- Temp (continuous): min -26°C (-15°F) max 104°C (220°F)
- Filter change out differential: 37-50 mbar over initial Δ P
- Polyester: 99%+ removal efficiency standard to 5 micron
- Paper: 99%+ removal efficiency standard to 2 micron

Options

- Swing bolts for heavy duty environments
- Epoxy coated housings
- Drain ports
- Spool piece extender on select models
- Pressure drop gauge

BSPP Inlet & Outlet	Assembly m ³ /h Rating	Assembly Part Number		Dimensions - mm				Suggested Service HT. E	Approx. Weight kg	Replacement Element Part No.		Element m ³ /h Rating
		Polyester	Paper	A	B	C	D			Polyester	Paper	
1"	68	ST-897-101C	ST-896-101C	340	303	178	264	228	5.0	897	896	196
1-1/4"	102	ST-897-126C	ST-896-126C	340	303	178	264	228	4.7	897	896	196
1-1/2"	136	ST-897-151C	ST-896-151C	340	303	178	264	228	4.6	897	896	196
2"	298	ST-851/1-201C	ST-850/1-201C	413	362	229	318	228	7.2	851/1	850/1	495
2-1/2"	357	ST-851/1-251C	ST-850/1-251C	413	362	229	318	228	6.8	851/1	850/1	495
3"	510	ST-235P-301C	ST-234P-301C	502	432	343	356	228	13	235P	234P	969
4"	884	ST-235P-401C	ST-234P-401C	502	432	343	356	228	11	235P	234P	969

CT Series Specifications

- Carbon steel black enamel drop down bucket
- Swing bolts standard on 6" housings

BSPP Inlet & Outlet	Assembly m ³ /h Rating	Assembly Part Number		Dimensions - mm				Suggested Service HT. E	Approx. Weight kg	Replacement Element Part No.		Element m ³ /h Rating
		Polyester	Paper	A	B	C	D			Polyester	Paper	
1"	68	CT-897-101C	CT-896-101C	340	300	178	264	228	5.4	897	896	196
1-1/4"	102	CT-897-126C	CT-896-126C	340	300	178	264	228	5.2	897	896	196
1-1/2"	136	CT-897-151C	CT-896-151C	340	300	178	264	228	5.1	897	896	196
2"	298	CT-851-201C	CT-850-201C	330	276	229	229	228	7.2	851	850	495
2-1/2"	357	CT-851-251C	CT-850-251C	330	276	229	229	228	6.8	851	850	495
3"	510	CT-235P-301C	CT-234P-301C	473	410	343	330	228	14	235P	234P	969
4"	884	CT-235P-401C	CT-234P-401C	473	410	343	330	228	12	235P	234P	969
6"	1870	CT-275P-601C	CT-274P-601C	483	368	483	251	254	20	275P	274P	1870

See Vacuum Filter Technical Data section for sizing guidelines.

Dimension tolerance ± 6 mm

Note: Model offerings and design parameters may change without notice. See www.solbergmfg.com for most current offering.

Extreme Duty Vacuum Filters SpinMeister™ ST Series

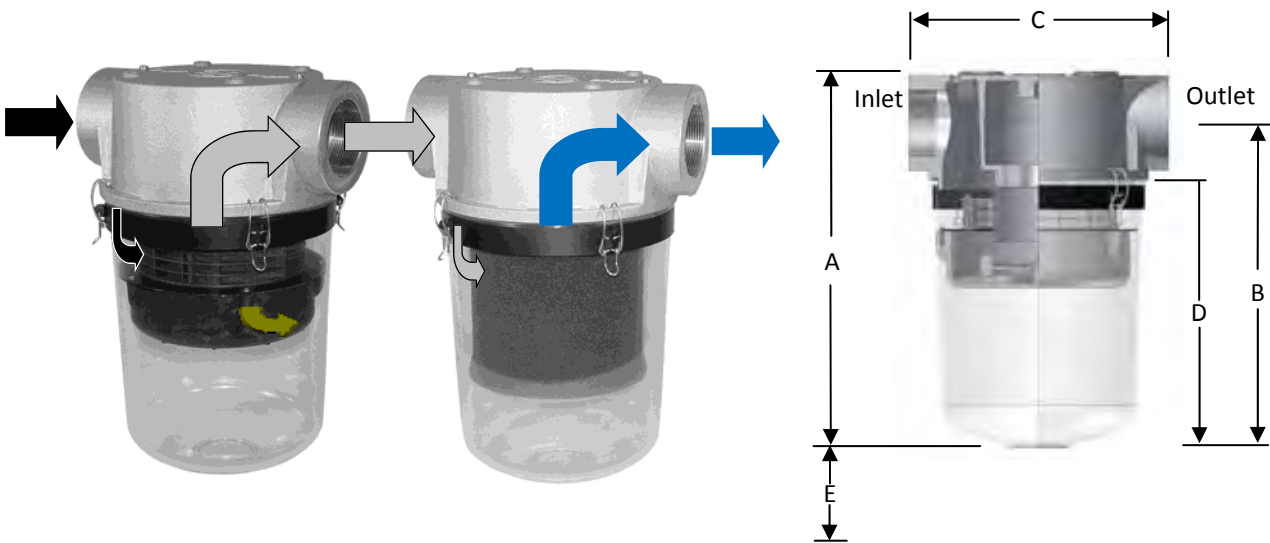

Operating Principle

- Centrifugal force from intake air causes particulate to separate from air stream, forcing it to the outer cover perimeter and out through the discharge port
- SpinMeister™ Precleaner eliminates large objects from entering air stream
- The air stream then enters the inlet filter and is filtered by a 99+% efficient pleated element

Technical Specifications

- Vacuum Rating: Gas tight seal
- Temp (continuous): min -26°C (-15°F) max 104°C (220°F)
- Filter change out differential: 37-50 mbar over initial ΔP
- Polyester: 99%+ removal efficiency standard to 5 micron
- Paper: 99%+ removal efficiency standard to 2 micron

Features

- Extreme duty filtration for high dust environments
- Excellent removal for short fibers
- Significantly increases life of filter element
 - SpinMeister™ Precleaner
 - 85+% efficient up to 15 microns
 - Made of durable molded fiber filled composite material
 - Reduced pressure drop
- Low pressure drop and positive sealing assembly
- Large dirt holding capacity
- Clip release shell for easy maintenance
- 6" SpinMeister™ housing has an extended shell

Options

- Multiple configurations
 - Inlet "L" design filters
 - Inlet filter assemblies
- SpinMeisters™ available in polished Aluminum
- Larger systems available
- Various media
- Spool piece extender on select models
- Pressure drop gauge

BSPP Connections

BSPP Inlet & Outlet	m ³ /h Rating		Assembly Part Number			Dimensions - mm				Suggested Service Area E	Replacement Element Part No.		Element m ³ /h Rating
	Range w/ SpinMeister	with Element	SpinMeister	Polyester Element	Paper Element	A	B	C	D		Polyester	Paper	
2"	68-187	298	ST-SML235-201C	ST-851/1-201C	ST-850/1-201C	413	362	229	318	228	851/1	850/1	495
2-1/2"	68-188	357	ST-SML235-251C	ST-851/1-251C	ST-850/1-251C	413	362	229	318	228	851/1	850/1	495
3"	170-340	510	ST-SML345-301C	ST-235P-301C	ST-234P-301C	502	432	343	356	228	235P	234P	969
3"	340-765	510	ST-SML445-301C	ST-235P-301C	ST-234P-301C	502	432	343	356	228	235P	234P	969
4"	170-340	884	ST-SML345-401C	ST-235P-401C	ST-234P-401C	502	432	343	356	228	235P	234P	969
4"	340-765	884	ST-SML445-401C	ST-235P-401C	ST-234P-401C	502	432	343	356	228	235P	234P	969
6"	765-1530	1870	CTD-SM6-601C**	CT-275P-601C*	CT-274P-601C*	483	368	483	251	254	275P	274P	1870

* Denotes housings with carbon steel buckets

** Denotes housings with carbon steel extended buckets

See Vacuum Filter Technical Data section for sizing guidelines.

Dimension tolerance ± 6 mm

Note: Model offerings and design parameters may change without notice. See www.solbergmfg.com for most current offering.



Note: Photo shown with optional equipment

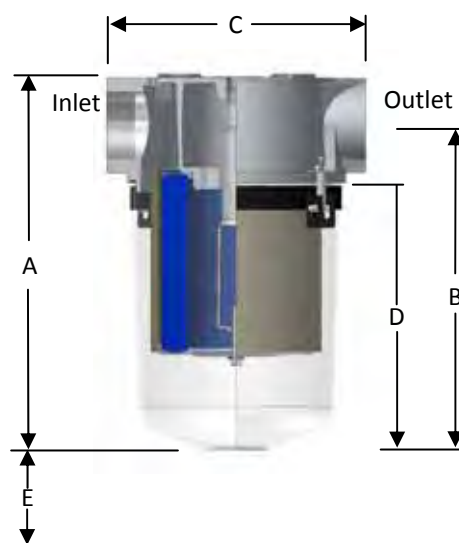

Operating Principle

- 3/4" tap on center of cast head for compressed air line or manual air hole which connects to center rod
- Center rod uses Reverse Pulse Technology to release bursts of air through the ID of the filter element; this drops dirt and debris to the bottom of the shell, extending service life of the filter element

Features

- See-Through polycarbonate bucket
- Resistant to electrical static build-up
- High tensile strength permits dimensional stability
- Integrated inlet baffle
- Sturdy swing "claw" bolts clamps bucket to head

Technical Specifications

- Vacuum Rating: Gas tight seal
- Temperature ratings:
 - Complete assembly max: 104°C (220°F)
 - See-through bucket only max: 125°C (257°F)

BSPP Connections

BSPP Inlet & Outlet	Assembly m ³ /h Rating	Assembly Part Number Polyester	Dimensions - mm				Suggested Service HT. E	Approx. Weight kg	Replacement Element Part No. Polyester	Element m ³ /h Rating
			A	B	C	D				
2"	298	RST-851/1-201C	413	362	229	318	228	7.2	851/1	495
2-1/2"	357	RST-851/1-251C	413	362	229	318	228	6.8	851/1	495
3"	510	RST-235-301C	502	432	343	356	228	13	235	969
4"	884	RST-235-401C	502	432	343	356	228	11	235	969

See Vacuum Filter Technical Data section for sizing guidelines.

Dimension tolerance ± 6 mm

Benefits

- Reduce downtime by eliminating need to shut down system to clean/check filter
- Filter elements last longer by blowing out media
- Maintenance checks are simplified with visual inspections
- Tested to withstand impacts and fractures at full vacuum

Options

- Accumulator tank
- Industrial hose coupling for compressed air line
- Electrical package to regulate compressed air pulse
- Contact factory about 1" to 1-1/2" sizes
- Carbon steel bucket configurations for heavy duty environments
- Alternative media: PTFE, Dutch Twill
- Spool piece extender on select models
- Pressure drop gauge

Inlet Vacuum Filters

Vacuum Filters for Medical (Non Sanitary) HV Series 1" – 4" BSPP



Industry Need

Vacuum filters for hospital non sanitary required work areas prevents damage to vacuum pumps and protects the work area environment from harmful contaminates. They are designed for the removal of liquids, solids, and sub-micron particles.

These high efficiency inlet vacuum filters are specifically designed for medical vacuum service on atmospheric air applications and can be used on a variety of vacuum pumps in most laboratory and hospital environments.

Features

- H14 UL media - 99.97% @ 0.1 micron
 - Low air to media ratio minimizes pressure loss for optimal pump performance
 - High dirt holding capacity
- Corrosion resistant cast aluminum head with integrated baffle
- "E.R." pressure drop indicator gauge; this "Easy Read" gauge provides color coordinated pressure drop readings
- High impact, shatter resistant see-through bucket
- Brass valve and fittings for contaminated liquid release
- Easy removable & serviceable sterilizable glass flask
- Certification: Contact factory

BSPP Outlet Connections (Contact factory for dimensions.)

BSPP Inlet & Outlet	Assembly m ³ /h Rating	Assembly Part Number	Approx. Weight kg	Replacement Element Part No.
1"	70	HV-UL896-101C	5	UL896
1-1/4"	70	HV-UL896-126C	4.7	UL896
1-1/2"	70	HV-UL896-151C	4.6	UL896
2"	175	HV-UL850/1-201C	7.2	UL850/1
2-1/2"	175	HV-UL850/1-251C	6.8	UL850/1
3"	340	HV-UL234/2-301C	13	UL234/2
4"	340	HV-UL234/2-401C	11	UL234/2

Dimension tolerance ± 6 mm

Note: Model offerings and design parameters may change without notice. See www.solbergmfg.com for most current offering.

Series Specific Application

- Designed specifically for use in laboratory and hospital work area environments
- Vacuum Pumps & Vacuum Systems

Options

- Vacuum Filter System (HVS Series)
- Contact factory about 1" to 1-1/2" sizes
- Support stand and protective shroud
- Carbon steel bucket for severe duty applications
- Oxygen rich systems-contact factory for specialized construction requirements
- Larger sizes, contact factory



Example: Custom Vacuum Filter System Design

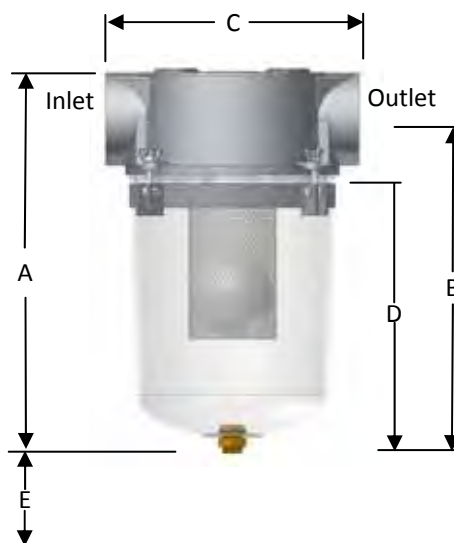

Operating Principle

- Inlet air with potentially harmful liquid and large particulate enters the housing and is separated by a baffling mechanism and directional air flow changes.
- The larger particles and liquid drops down and collects at the bottom of the separator.
- The float ball within the separator screen rises with the liquid level until max capacity and cuts off the flow thereby protecting the pump from damage.

Features

- High impact, shatter resistant, polycarbonate bucket
- Corrosion resistant cast aluminum head with integrated knock-out baffle
- Cast head with tap hole guides for mounting brackets (2" - 4" size)
- Stainless steel float ball for emergency shut off
- Stainless steel perforated float ball tube (stainless steel expanded metal tube for 1" - 1-1/2" size)
- Clamp style T-bolts standard
- Temperature ratings: max 125°C (257°F)
- 1/2" drain
- 1/4" differential gauge ports 2" to 4"

BSPP Connections

BSPP Inlet & Outlet	Assembly m ³ /h Rating	Assembly Part Number	Dimensions - mm				Suggested Service HT. E	Holding Capacity (liter)
			A	B	C	D		
1"	68	STS-101C	340	303	178	264	228	1.6
1-1/4"	102	STS-126C	340	303	178	264	228	1.6
1-1/2"	136	STS-151C	340	303	178	264	228	1.6
2"	297	STS-201C	413	362	229	318	228	1.9
2-1/2"	356	STS-251C	413	362	229	318	228	1.9
3"	510	STS-301C	502	432	343	356	228	5.7
4"	850	STS-401C	502	432	343	356	228	5.7

Benefits

- Prohibit liquid and debris from damaging vacuum valves and pumps
- Easy visual inspection with see-through housing
- Minimize piping costs with "T" style configuration
- Compact design for space restricted work areas

Options

- Float level port/switch
- Cast head protective coatings: stainless steel, epoxy finish, PTFE
- Heavy duty carbon steel buckets available
- Spool piece extender on select models
- Pressure drop gauge
- Contact factory about 1" to 1-1/2" sizes

Vacuum Filtration for Solar, Semi-con, LED, Coating



Protecting Pumps & Systems

We offer inlet and discharge filtration solutions for the complete assortment of vacuum equipment found in solar, semi-con, LED, & coating manufacturing processes. Inherent in these processes are a range of filtration challenges from capturing abrasive dust particles to managing pyrophoric or hazardous materials.

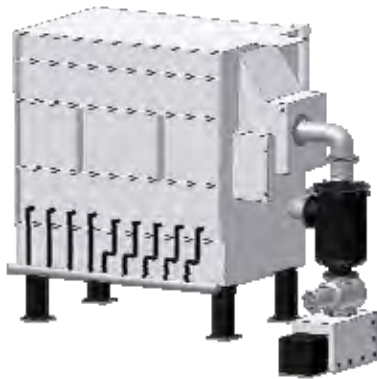

Vacuum Furnace
High Efficiency Particulate
Vacuum Filters



Crystal Growing
Mono/Single Crystalline
Reverse Pulse Vacuum Filters

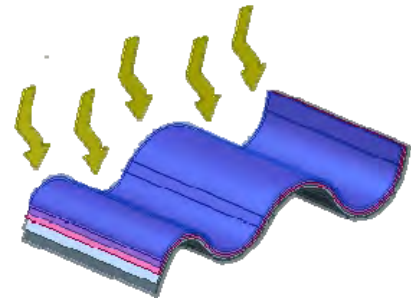

Vacuum Coating
Sputtering, Etching
Foreline Traps, Filters,
Discharge Eliminators

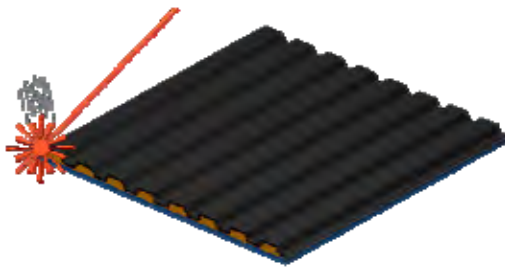

Material Processing & Handling
Ablation, Edge Deletion, Scribing, Vacuum Lifting
Inlet Vacuum Filters

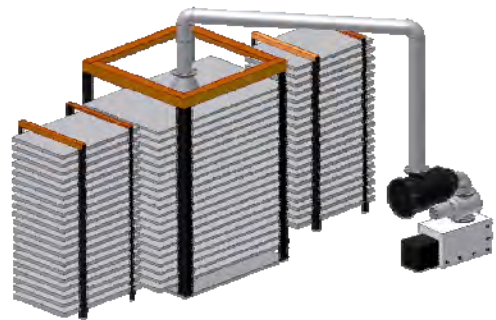

Oven Lamination
Heavy Duty Inlet Vacuum Filters



ISO Flange Inlet Filters
Polycrystalline Ingot,
Vacuum Coating, Lamination



Oil Mist Filters
Vacuum Coating
Discharge of Vacuum Pumps



Heavy Duty Inlet Filters
Oven Lamination,
Vacuum Furnaces



Reverse Pulse Filters
Mono/Single Crystalline
Manufacturing

Inlet Vacuum Filters



Operating Principle

- Reverse Pulse Technology extends maintenance intervals and improves process productivity by rapidly introducing atmospheric air or inert gas into the system.
- This process purges dust from loaded filters and allows the particles to settle in the bottom chamber for easy disposal.

Features

- Integrated reverse pulse technology unloads and extends filter life improving maintenance intervals and process run time
- Interchangeable filter element provides for easy replacement
- Integrated support stand
- Removable base for easy cleaning access
- Carbon steel or stainless steel housing construction
- Contact factory for model offering and availability.

Technical Specifications

- Vacuum Leak Rate: 1×10^{-5} mbar l/sec
- PTFE media: 99.5% efficiency @ 0.3 micron
Temperature (continuous): 135°C (275°F)
- Dutch Twill media: 99.5% efficiency @ 1 micron
Temperature (continuous): 176°C (350°F)
- Face Velocity @ .10 m/sec (20 ft/min)

Note: Model offerings and design parameters may change without notice.

Series Specific Applications

- Vacuum furnaces for crystal growing, steel, titanium, etc.
- Vacuum coating and lamination
- Wet & dry vacuum pumps & systems
- Compatible with most dopants
- Safeguard pumps from harmful particles (SiO_x , GAN, etc.)
- Prevent particles from contaminating pump oil
- Reduce risk of backstreaming
- Prevents build up and seizing in dry pumps

Benefits

- Extends filter life improving maintenance intervals and process run time
- High conductance design
- Lower costs from unnecessary piping
- Large liquid/slurry holding capacity
- Easy maintenance (removable base)
- Reduced footprint

Options

- Multiple designs to meet application specific requirements
- Industrial coatings: PTFE, epoxy
- Finishes: passivation, bead blasting
- Certifications ASME, PED, ATEX
- Parallel filtration systems
- Valves for semi or fully automated system operation
- Flange connection variations and design orientation
- Vacuum Leak Rating: 1×10^{-8} mbar l/sec

Liquid Separator/Vacuum Filter LRS/SRS Series 3/4" - DN250

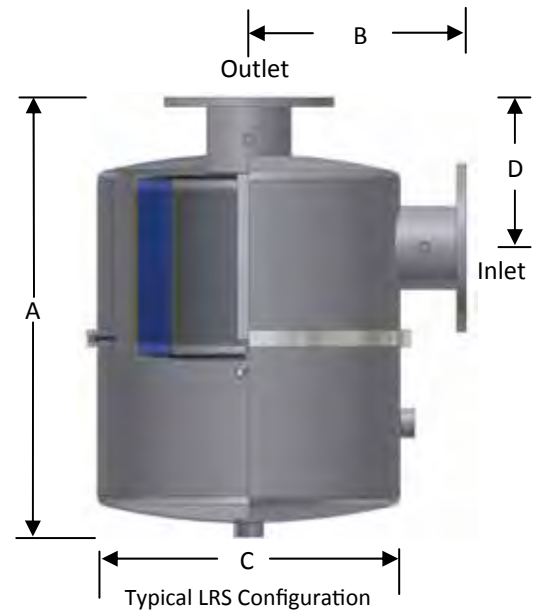

Operating Principle

- The inlet air with potentially harmful liquids and particulate enters the highly efficient vacuum filter and is separated by a baffling system.
 - The larger particles and liquid drop down to the large capacity lower chamber.
 - The lower chamber has significant liquid/slurry holding capacity & has an optional removable base for easy cleaning.
 - The final stage has a replaceable filter element for fine filtration that is 99+% efficient before it reaches the vacuum pump.
- Note: A typical SRS Series design has a pre-separator demister or strainer element before the filter element for additional liquid/particulate removal.

LRS Series Specifications

- "L" style configuration: side inlet, top outlet
- Multiple stage filtration:
 - Baffle System
 - 99+% efficient filter element
- For aerosol apps, additional knock out pot or separator is unnecessary
- Compact construction design

SRS Series Specifications

- Offset connections: lower side inlet, upper side outlet
- Multiple stage filtration
 - Integrated baffle system
 - Pre-Separator demister or stainless steel wire mesh strainer
 - Primary 99+% efficient filter element
- Additional knock out pot or separator unnecessary
- Significant liquid/slurry holding capacity
- Removable base option for easy access cleaning
- Brackets for support legs & nameplate
- Lifting lugs

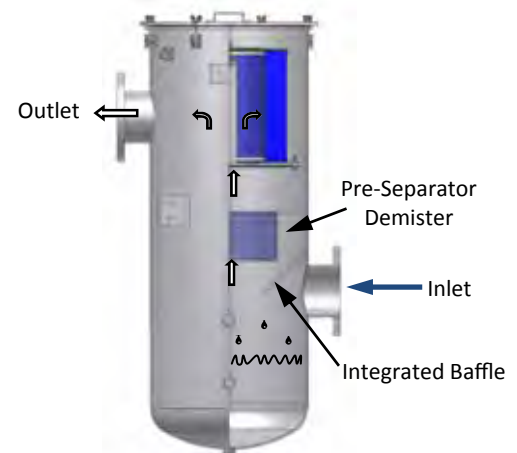

SRS with demister option

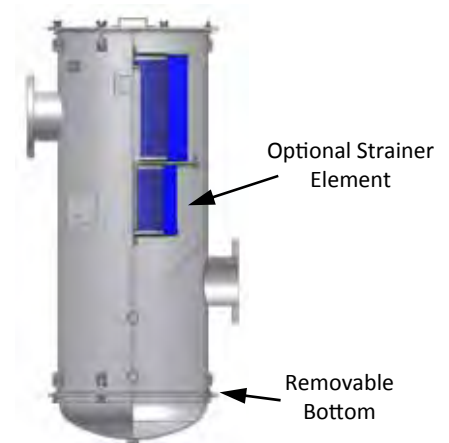

SRS with strainer element option

Inlet Vacuum Filters

Benefits

- Simplified vacuum package: 2 functions in one (liquid separator & inlet air filter)
- High efficiency separation & multistage filtration
- Protects pump from harmful liquids that destroy lubricating/sealing oil
- Lower costs from unnecessary piping
- Large liquid/slurry holding capacity
- Prevents emulsification of oil in oil lubricated systems
- Reduced footprint

Features

- Durable carbon steel construction with blue epoxy coating
- Baffle system
- Significant liquid/sludge holding capacity
- 1/4" inlet/outlet taps on 3" and larger
- 1" sight port for visual inspection
- 1" drain port
- Wide range of operation flows

Technical Specifications

- Vacuum Rating: Gas tight O-ring seal
- Filter change out differential: 37-50 mbar over initial ΔP
- 99% liquid removal efficiency
- Polyester: 99%+ removal efficiency standard to 5 micron

Options (Inquires Encouraged)

- ATEX certified housings
- PED & ASME rated vessels
- Multiple configurations
- Extended bucket for additional holding capacity
- Wire mesh strainer element
- Removable bottom for full access cleaning
- Stainless steel construction
- Safety switch port for high liquid warning
- Vacuum gauge
- Support legs and lifting lugs
- Electronics package (customer specified)

LRS Series

Assembly m ³ /h Rating	Inlet / Outlet Size	Inlet / Outlet Type	Assembly Part Number	Dimensions - mm				Approx. Holding Capacity L	Replacement Element Part No.	Element m ³ /h Rating
				A	B	C	D			
105	3/4"	FPT	LRS-19-075HC	454	118	195	89	5.7	19	170
145	1"	BSPP	LRS-19-101HC	454	118	195	89	5.7	19	170
145	1 1/4"	BSPP	LRS-19-126HC	454	118	195	89	5.7	19	170
170	1 1/2"	BSPP	LRS-19-151HC	454	118	195	89	5.7	19	170
230	2"	BSPP	LRS-237-201HC	565	171	305	163	9.5	237	935
335	2 1/2"	BSPP	LRS-237-251HC	578	184	305	163	9.5	237	935
510	3"	BSPP	LRS-237-301HC	578	184	305	163	9.5	237	935
885	DN100	FLG	LRS-275-DN100	594	292	406	203	17	275	1870
1415	DN150	FLG	LRS-275-DN150	594	292	406	203	17	275	1870

See Vacuum Filter Technical Data section for sizing guidelines.

Dimension tolerance ± 6 mm

SRS Series (Contact factory for dimensions, more sizes available)

Assembly m ³ /h Rating	Flange Inlet & Outlet	Reference Only Assembly Part Number	Approx Holding Capacity L	Replacement Element Part No.
2170	DN150	SRS-377/274S-DN150	76	377/274S
3060	DN200	SRS-385/376S-DN200	170	385/376S
3060	DN250	SRS-385/376S-DN250	170	385/376S

PN10 Pattern Flange Outlet Connections

PN10 Pattern Flange	Dimensions - mm			No. of Holes	Thickness Fig mm
	O.D.	B.C.	B.H.		
DN100	220	180	18	8	20
DN150	285	240	22	8	22
DN200	340	295	22	8	24
DN250	395	350	22	12	26

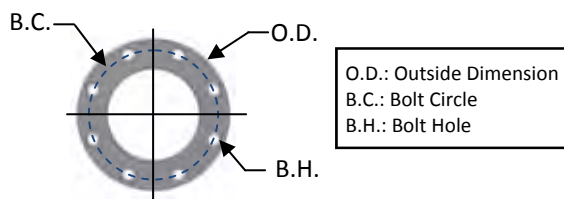

All flanges are orientated "split center".

Note: Model offerings and design parameters may change without notice. See www.solbergmfg.com for most current offering.

Natural Gas Filtration Suction/Interstage Scrubbers

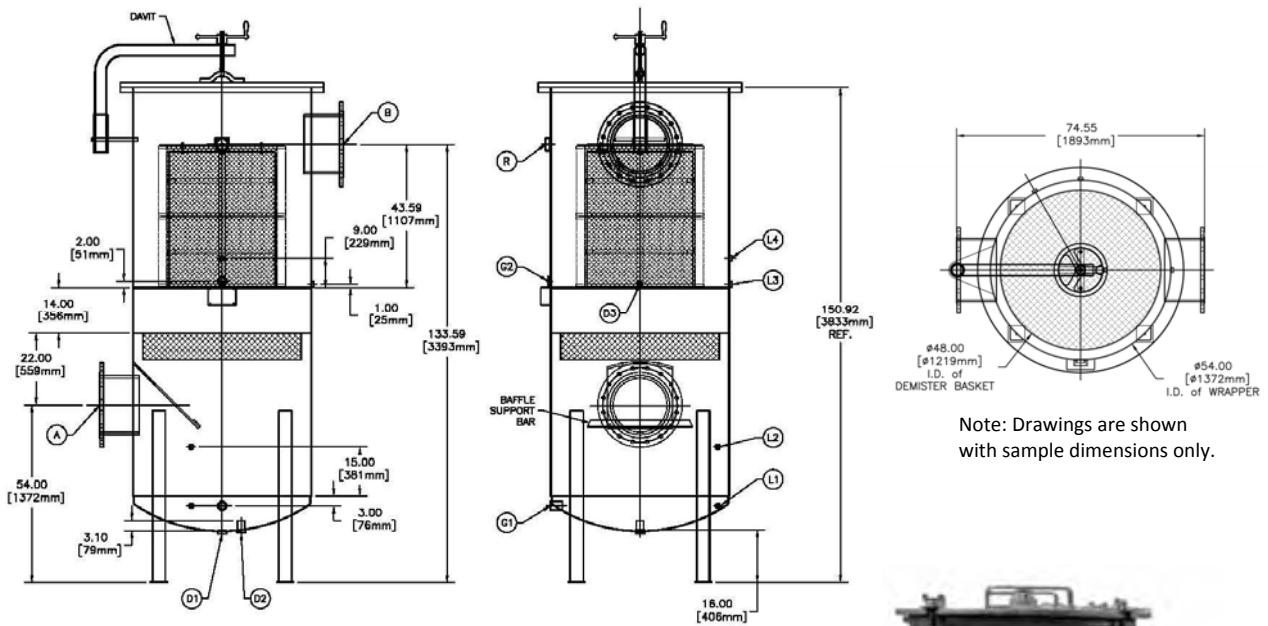

Note: Drawings are shown with sample dimensions only.

Series Specific Applications

- Landfill and Bio-Gas recovery
- Fuel for reciprocating engines and gas turbines
- Gas compression
- Compressor packages
 - Rotary Screw
 - Centrifugal
 - Reciprocating
 - Vane

Features

- Protects equipment from condensate, oil, and particulate entrained in the gas stream
- Multi-stage separation
 - 316 SS vane pack or demister pad for heavy condensate and oil removal
 - High efficiency 99+% final filter elements
- Rugged carbon steel construction
- Contact factory for model offering and availability



Options

- Special standards: PED, ATEX, ASME Vessel code sec. VIII division I
- Stainless steel construction
- Special coatings or finishes
- Replaceable filter elements in various efficiencies for particulate removal
- Gauge ports, float switches
- Custom leg supports
- Flush port for vessel cleaning
- Removable vessel lid for element service
- Davit arm for vessel lid removal



Note: Model offerings and design parameters may change without notice. See www.solbergmfg.com for most current offering.



Vacuum Gauges

- Monitors amount of restriction across the filter assembly or element
- Convenient and inexpensive way to assure maximum usage from filter element
- 1/4" connection
- 0-760mm Hg (0-30" Hg)
- Available in 2 designs: back-mount or bottom mount
- To be used on CSL, CT/ST Series
- Contact factory for model offering and availability



Differential Vacuum Gauge

- Indicates pressure drop across the filter assembly or filter element
- Shock and vibration resistant
- Frost-proof manometer fluid does not evaporate or cause toxic fumes
- To be used on CSL & HDL Series
- Contact factory for model offering and availability



EZ Read Pressure Drop Gauge

- Gauge Kit includes: gauge, connectors, mounting bracket, clear, flexible hoses
- To be used on ST, CT and HV series
- Contact factory for model offering and availability

Notes



Inlet Vacuum Filters

